

KORG[®]

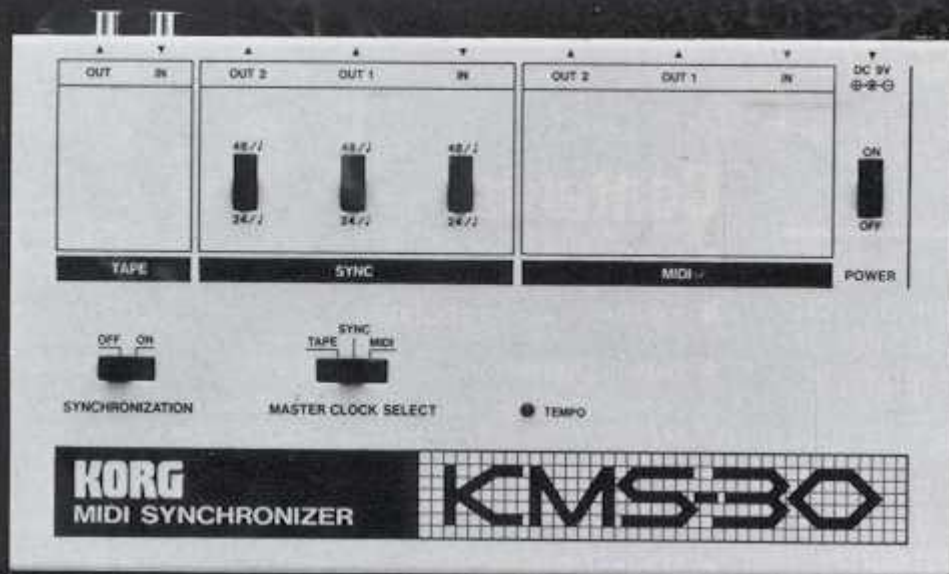

KMS-30

MIDI SYNCHRONIZER

OWNER'S MANUAL

Thank you for purchasing the Korg KMS-30. To assure optimum performance and long-term reliability please read this manual carefully before using this unit.

KMS-30 Overview

For synchronized operation of rhythm machines, sequencers, and other equipment, you need to use some sort of timing signal. MIDI or sync signals can be used to carry this timing information.

Although MIDI and sync signals both use DIN connectors, the signal formats are quite different. To synchronize an instrument that uses MIDI with one that uses sync, you must convert each type of signal into the other.

The KMS-30 is an interface designed for this purpose. It can convert "clock signals" between MIDI and sync signal formats. It can also handle tape sync (TAPE CLOCK) and MIDI start and stop commands.

The KMS-30 handles these three kinds of signals:

1. SYNC (24/48 clock pulses per beat)
2. MIDI (Start, stop, clock)
3. TAPE CLOCK

Contents

● Precautions	3
● Features and Functions	4
● Basic Operation	6
1 Sequencer as master, rhythm machines as slaves.	
2 Rhythm machine as master, sequencers or rhythm machines as slaves.	
3 Tape clock as master, sequencers or rhythm machines as slaves.	
● Typical Setups	12
● Specifications / Options	13

Precautions

Please read and observe the following precautions to assure reliability and safety.

■ LOCATION

To avoid malfunction, do not use this unit in the following locations for long periods of time:

- In direct sunlight.
- Exposed to extremes of temperature or humidity.
- In sandy or dusty places.

■ HANDLE GENTLY

Knobs and switches are designed to provide positive operation with a light touch. Excessive force may cause damage.

■ MAINTENANCE

Wipe the exterior with a soft, dry cloth. Never use paint thinner, benzene or other solvents.

■ ELECTRICAL INTERFERENCE

This unit is subject to interference from other electrical devices and fluorescent lamps. Avoid use near other appliances. Should interference occur, try placing further away from the source of trouble. Since this unit employs digital signals, interference may result in erratic performance in equipment to which it is connected. In this case turn off the power on this and connected equipment. Wait a few seconds, then turn the power back on.

■ POWER SUPPLY

Use the supplied AC adaptor. Do not use any AC adaptor other than the one that comes with the KMS-30.

■ WARRANTY

For fullest warranty protection, return your properly filled in warranty card.

■ KEEP THIS MANUAL

Store this manual in a safe place for future reference.

Features and Functions

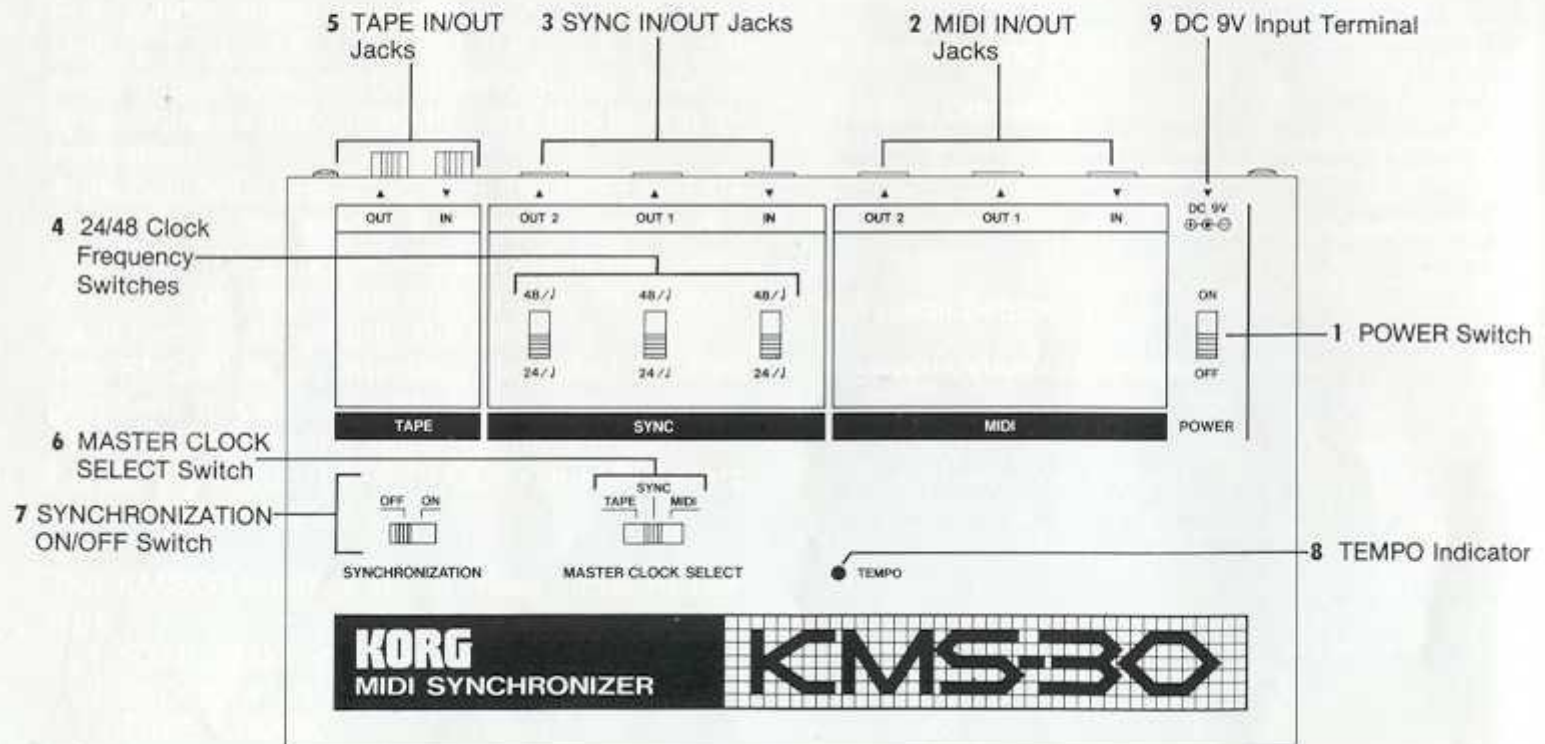

Features and Functions

1 POWER Switch

Turn on the power on the KMS-30 after you have checked connections to all other equipment. The TEMPO indicator LED (light-emitting diode) comes on when the power is on.

2 MIDI IN/OUT Jacks

Used for MIDI signal connections from MIDI equipped sequencers, synthesizers, and so on. For example, you can use a MIDI sequencer for synchronized operation with a non-MIDI rhythm machine. Or you can use these as MIDI THRU jacks (when the MASTER CLOCK is set to MIDI).

IN: Connects to a MIDI OUT jack (on a sequencer, etc.)

OUT1/OUT2: These jacks output a MIDI signal that contains clock and start/stop data. These become MIDI THRU jacks if the MASTER CLOCK is set to the MIDI position.

3 SYNC IN/OUT Jacks

For connection of non-MIDI equipment. The KMS-30 will convert sync signals (from conventional rhythm machines or sequencers) and produce a synchronized MIDI signal for control over MIDI equipped units. It will also work the other way around.

IN: Takes the sync signal output from a non-MIDI rhythm machine or sequencer.

OUT1/OUT2: These jacks output a sync signal for control over non-MIDI units. The sync clock frequency can be set to either 48 or 24 (per quarter note or beat).

4 24/48 Clock Frequency Switches

Set to the clock frequency that matches the connected equipment. Refer to that equipment's owner's manuals for details. Korg rhythm machines use a sync clock frequency of 48.

5 TAPE IN/OUT Jacks

These are for multi-track recording. First, you record a TAPE CLOCK click track on one track of the tape. This is provided at the TAPE OUT jack and derived from a sequencer or rhythm machine input (sync or MIDI signal.) Then for your overdubs you play back the tape, routing the click track to the TAPE IN jack. This then becomes the master controller for MIDI and sync outputs on the KMS-30.

IN: For tape playback. This jack connects to the tape recorder's output jack (for the track on which you record the KMS-30 TAPE CLOCK click track signal).

OUT: For tape recording. Connect this to the tape recorder's input (for the track that you will use to record the click track signal). The signal at this jack is produced by processing the MIDI or sync clock signal so that it can be easily recorded on tape.

6 MASTER CLOCK SELECT Switch

Selects which of the three kinds of possible clock input signals, MIDI, SYNC, or TAPE, will be used as the master clock for the KMS-30 output signals.

Features and Functions

7 SYNCHRONIZATION ON/OFF Switch

This can be set to enable or disable synchronized input and outputs to units connected to the KMS-30.

OFF: This turns off all synchronization signals. At this position the TEMPO LED will stay lit and connected equipment will not be synchronized.

ON: At this position connected units will operate in sync with the clock signal selected by the MASTER CLOCK SELECT switch. The TEMPO LED will flash in time with the tempo.

8 TEMPO Indicator

This LED flashes in time with the beat (quarter note).

9 DC 9V

Connect the supplied AC adaptor to this input.

Basic Operation

1. Sequencer as master, rhythm machine as slave. (MASTER CLOCK = MIDI)

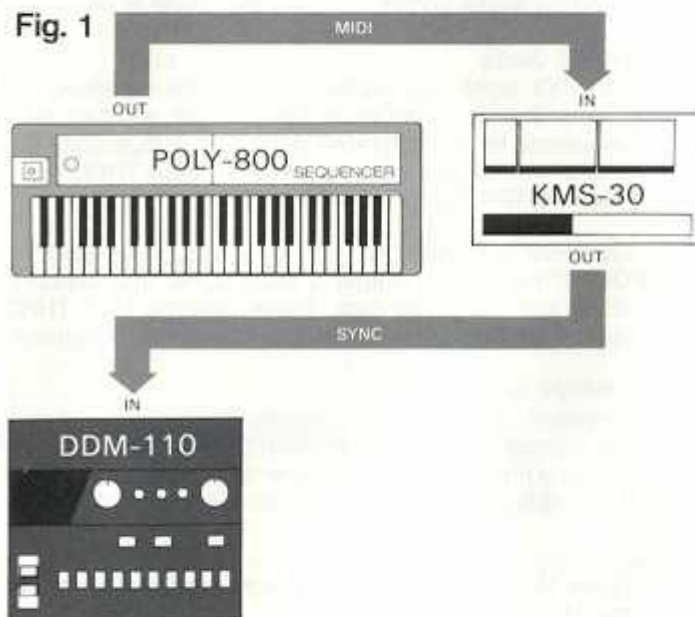

Example: (Fig. 1)
Using the Korg Poly-800's built-in sequencer for control of a rhythm machine (Korg DDM-110).

Basic Operation

● Procedure (Fig. 1)

- 1 Use a standard MIDI (DIN) cable to connect the Poly-800's MIDI OUT jack to the KMS-30's MIDI IN jack.
- 2 Use a standard DIN cord (NOTE: Certain MIDI spec DIN cables which only have pins 2, 4 and 5 connected will not work for sync connections.) to connect the KMS-30's SYNC OUT jack to the SYNC IN jack on the rhythm machine (DDM-110, etc.).
- 3 Set the 24/48 clock switch to 48 (for Korg equipment) for the SYNC OUT jack that you are using.
- 4 Set the MASTER CLOCK SELECT switch to MIDI. Set the SYNCHRONIZATION switch to ON.
- 5 Start the Poly-800's sequencer. The rhythm machine will play along in perfect time because the KMS-30 converts the MIDI signal's clock and start/stop data into a sync signal that the rhythm machine can understand.

Here the MIDI signal at the KMS-30 MIDI OUT jacks contains all of the MIDI data from the Poly-800, not just clock and start/stop information. That is, the MIDI OUT jacks are acting like MIDI THRU jacks.

Since the MIDI OUT jacks also work as MIDI THRU jacks in this situation, it follows that you can use the KMS-30 as an expander unit for connection of other MIDI equipped synths and rhythm machines. If the additional unit has a MIDI IN jack then it can be connected to one of the KMS-30 MIDI OUT jacks.

An example of connection by using the MIDI THRU jacks

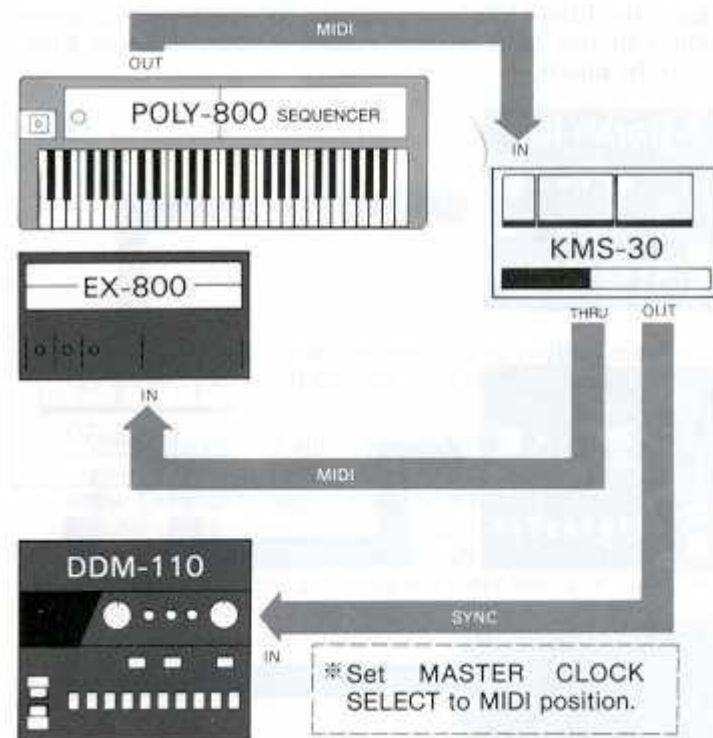

Basic Operation

2. Rhythm machine as master, sequencers or rhythm machines as slaves. (MASTER CLOCK = SYNC)

Example: (Fig. 2)

Using the DDM-110's internal clock for synchronized operation with two other rhythm machines (DDM-220 and KPR-77 in the chart).

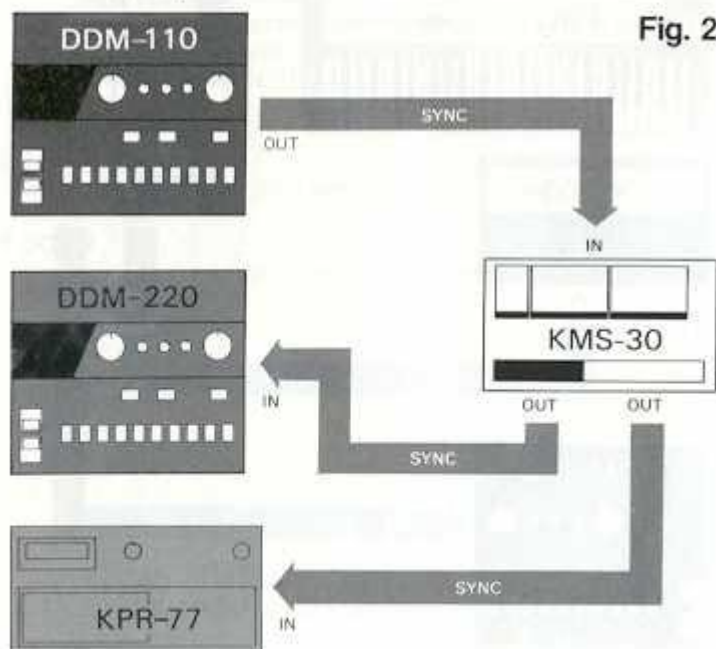

Fig. 2

● Procedure (Fig. 2)

- 1 Use a DIN cord to connect the DDM-110 SYNC jack to the KMS-30 SYNC IN jack.
- 2 Use DIN cords to connect the KMS-30 SYNC OUT jacks to the SYNC jacks on the other rhythm machines.
- 3 Set all three 24/48 clock frequency switches to the 48 position.
- 4 Set MASTER CLOCK SELECT to the SYNC position. Set the SYNCHRONIZATION switch to the ON position.
- 5 Start the DDM-110. The other rhythm machines will play along in time (and according to their programmed patterns). Adjust tempo on the DDM-110.

Control can be extended to include a digital (MIDI) sequencer as described below. (Fig. 3)

Besides the DDM-110, which acts as the master, and two rhythm machines that operate on sync signals, you can also connect a MIDI equipped digital sequencer's MIDI IN jack to one of the KMS-30 MIDI OUT jacks as shown in Fig. 2.

Basic Operation

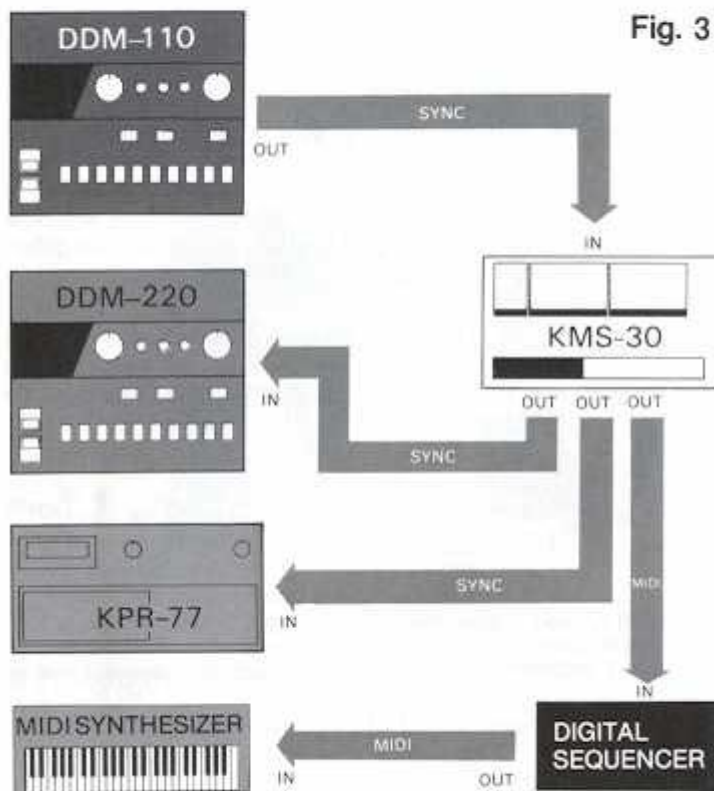

The digital sequencer will respond only to the clock and start/stop data from the DDM-110 since that is all that is included in the MIDI signal at the KMS-30 MIDI OUT jacks.

3. Tape clock as master, sequencers or rhythm machines as slaves. (MASTER CLOCK = TAPE)

With this kind of setup you can first record your basic rhythm track together with a kind of click track (that is, the TAPE OUT signal from the KMS-30). Then for overdubs you can synchronize your rhythm machines, sequencers, and synthesizers to play along in perfect time, since they are controlled by the playback click track. For home multi-track recording, this is a convenient way of creating a demo with a complex rhythm section accompaniment.

Basic Operation

1 Recording the click track (TAPE CLOCK)

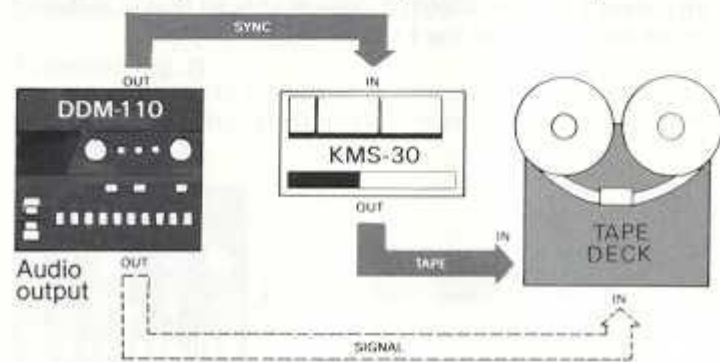

● Procedure

- 1 Connect the DDM-110's sync jack to the SYNC IN jack of the KMS-30. Set the SYNC IN jack's switch to 48.
- 2 Use a home hi-fi system cord (RCA phono cord) to connect the KMS-30 TAPE OUT jack to the track-1 input of your multi-track tape recorder.
- 3 Connect the audio signal output(s) (stereo, L, R, etc.) from the DDM-110 to another track or tracks on the tape recorder.
- 4 Connections are now complete. Follow the three steps below for recording:

- 1 Set MASTER CLOCK SELECT to SYNC. Begin recording for a few seconds before starting the DDM-110. (In this situation the KMS-30 outputs a high-pitched leader tone. Adjust the recording level so that the meter gives a reading between 0 and -3dB (or 0VU .)
- 2 Start the DDM-110. (The TAPE OUT jack will now output a sync signal that will sound like two different pitched signals rapidly alternating.)
- 3 At the end of the DDM-110 performance, continue recording for a few seconds. As in the beginning this will result in a leader tone being recorded on the tape.

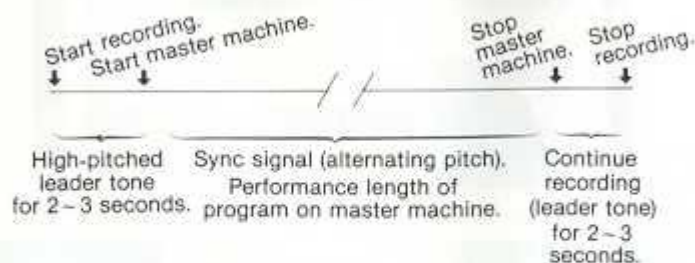

Basic Operation

2 Tape Clock (click track) Playback with Overdubbing

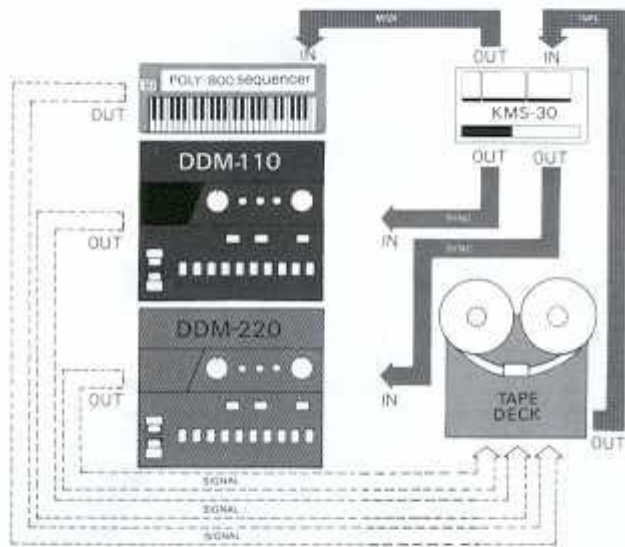

● Procedure

- 1 Connect the output of the recorded click track (we assume track one) to the TAPE IN jack on the KMS-30. Use an RCA phono cord (the kind of cord used for connections between components in a home hi-fi system).

- 2 Connect rhythm machines and sequencers to the KMS-30 MIDI OUT and SYNC OUT jacks.
- 3 Set the SYNC switches to 48 if using Korg equipment.
- 4 Connect the audio signal outputs (stereo, L, R, or whatever they're called) to available track inputs on the tape recorder.
- 5 Set MASTER CLOCK SELECT to TAPE; SYNCHRONIZATION ON.
- 6 Playback the track that you recorded the tape clock output on. When the sync signal begins, your connected equipment will begin playing along in time.
- 7 At the same time, record the audio output signals from the connected equipment on other tracks.
- 8 After recording, you can change the programmed patterns on the connected equipment and overdub again (and again, depending on how many tracks you have on your tape recorder).

The tape clock output signal is set at standard line level. As with any signal it will become distorted if you set recording level too high on your multi-track tape recorder. If the signal is distorted then there may be problems during playback and overdubbing. (0 — -3 dB)

Playback level is set to same level with recording (0 — -3 dB).

Typical Setups

Typical Setups

There are many possibilities with the KMS-30. The chart here shows an elaborate system for multitrack recording. When the MASTER CLOCK is set to MIDI then the MIDI OUT jacks work as MIDI THRU jacks, outputting all data from the Poly-800.

In this example, the idea is to first record the TAPE CLOCK output along with the initial Poly-800 audio output (on tracks 1 and 2, for example). Then go on to record rhythm machines and synth overdubs as slaves to the TAPE CLOCK playback (making sure that this time you have the MASTER CLOCK set to TAPE).

Note: At this point you will no longer be able to slave other units to a SYNC or MIDI clock (by setting the MASTER CLOCK to MIDI) since this will not necessarily coincide exactly with what you have already recorded on the tape.

Another tape sync function especially useful in multi track home recording where extra tape tracks are not available is recording MIDI and sync devices during the mix. This reduces the necessity for overdubbing and, therefore, signal loss in subsequent taping generations. To do this, record the sync tone (on track 1) after all sync and MIDI devices are programmed properly. Record other instruments and vocals on separate tracks while listening to the instruments synced with the KMS-30 (MASTER CLOCK set to tape). Then mix the MIDI and sync devices onto the "master" tape during mixdown.

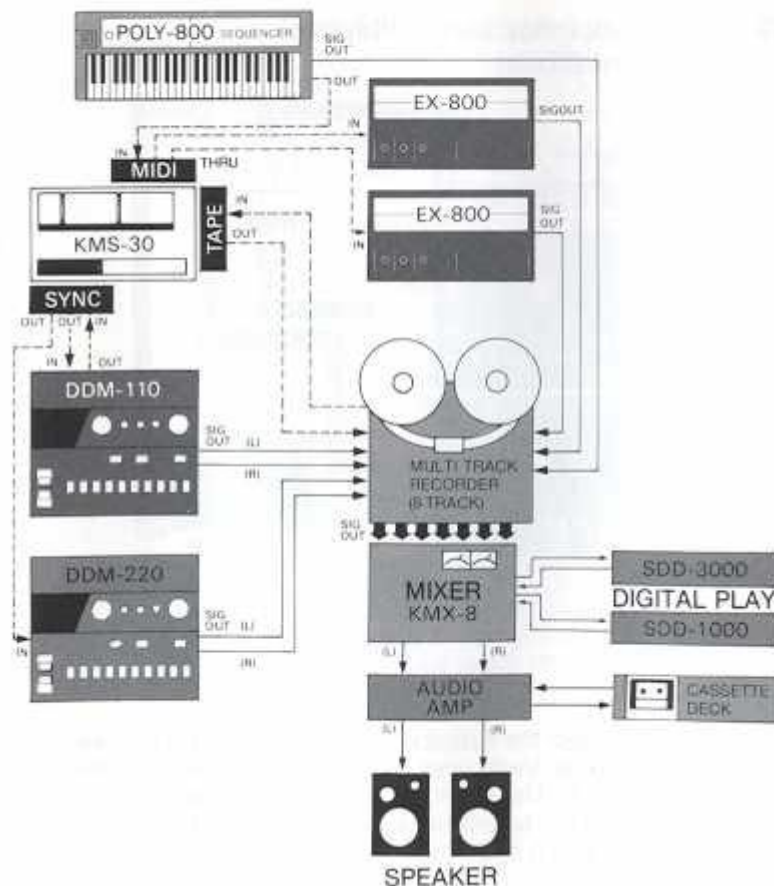

Specifications/Options

MIDI Section

MIDI IN × 1
MIDI OUT × 2
(MIDI OUT jacks act as MIDI THRU when MASTER
CLOCK is set to MIDI.)

SYNC Section

SYNC IN × 1
SYNC OUT × 2
24/48 Clock Frequency Switches × 3

TAPE Section

TAPE IN × 1
TAPE OUT × 1
(RCA Phono Jacks; Line Level)

SYNCHRONIZATION

ON/OFF × 1

MASTER CLOCK SELECT

MIDI/SYNC/TAPE Selector × 1

TEMPO

LED Indicator × 1

POWER

ON/OFF × 1

Input/Output Jacks

MIDI IN × 1 (DIN Jack)
MIDI OUT × 2 (DIN Jacks)
SYNC IN × 1 (DIN Jack)
SYNC OUT × 2 (DIN Jacks)
TAPE IN × 1 (RCA Phono Jack)
TAPE OUT × 1 (RCA Phono Jack)
DC 9V IN × 1

Dimensions

232(W) × 35(H) × 131(D) mm

Weight

850g

Supplied Accessories

AC Adaptor (9V) × 1

Options

MIDI CABLE

MEMO

N O T I C E

Korg products are manufactured under strict specifications and voltages required by each country. These products are warranted by the Korg distributor only in each country. Any Korg product not sold with a warranty card or carrying a serial number disqualifies the product sold from the manufacturer's/distributor's warranty and liability. This requirement is for your own protection and safety.

KORG[®]

KEIO ELECTRONIC LABORATORY CORPORATION
15-12, Shimotakaido 1-chome, Suginami-ku, Tokyo, Japan

©KEIO ELECTRONIC LABORATORY CORP. 1984

5908ETH PRINTED IN JAPAN